

Mechanical engagement gearboxes

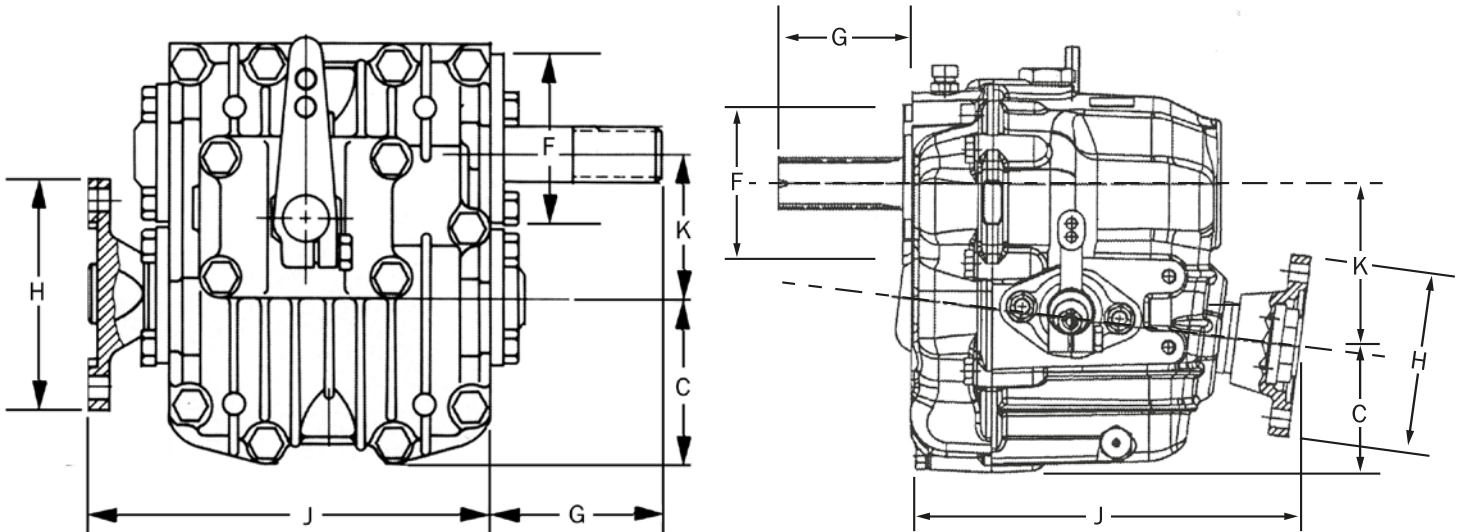

Make ZF (PREVIOUS HURTH HBW TYPES)

Model		10M** (100)	12M (125)	15M (150)	15MIV (150V)	15MA (150A)	25M (250)	30M
REDUCTION		-		1.56 ^o			-	
RATIOS :1		(1.86 ^A)	(1.95 ^A)	1.88 ^o	2.13 ^o	1.88 ^o 2.14 ^o	1.88 ^o	2.15 ^o
^A As engine rotation		2.05 ^o	2.14 ^o	(1.95 ^A)	(2.22 ^A)2.72 ^o	(1.95 ^A)	(2.10 ^A) 2.27 ^o	(2.64 ^A)
^o Opposite rotation		(2.72 ^o)	(2.63 ^o)		(2.99 ^o)	2.63 ^o	(2.74 ^o)	2.70 ^o
Weight	W Kgs	10	13	13	20	13	18	33
Length	J mm	180	192	192	265	194	218	254
Drop	K mm	62	72	72	147 at 15°	94 at 8°	85	90
Depth	C mm	73	86	86	106	76	93	94
Spigot	F mm	88	88	88	88	88	92	92
Shaft	G mm	75	75	75	75	75	83	62
Flange	H ins	4	4	4	4	4	4	4
Max Diesel HP/100*		1.4(0.9)	1.8(1.5)	2.0	2.0(1.5)	2.0(1.5)	3.6(2.4)	3.2(2.6)
Max RPM		5000	5000	5000	5000	5000	5000	5000
Cooler size		H	H	H	H	H	H	H
Lubricant		Automatic transmission fluid, Dextron ZF 12M, 15M and 25M gearboxes may be ordered for non-standard input rotation May be locked in astern or trailed while sailing Made in European Community						

*Pleasure boat rating for 4 cylinder engines. 2 or 3 cylinder ratings are lower

**No longer available. Information given for comparison purposes

Lancing Marine are able to modify any of these boxes for horizontal offset at extra charge

Installation parts available include:- Flywheel housings and adaptors, flywheel drive plates, oil coolers, shift cable connection kits, flexible couplings, shaft half couplings, C.V shafts and thrust bearings

All gearboxes may be operated with single lever remote controls, and will accept

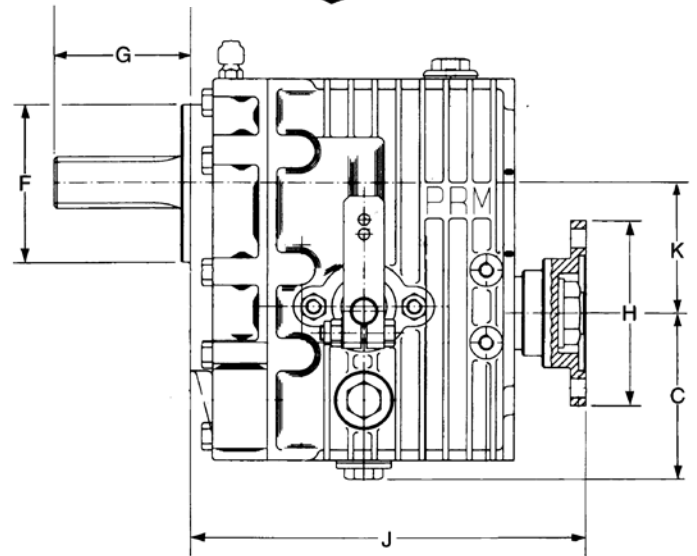
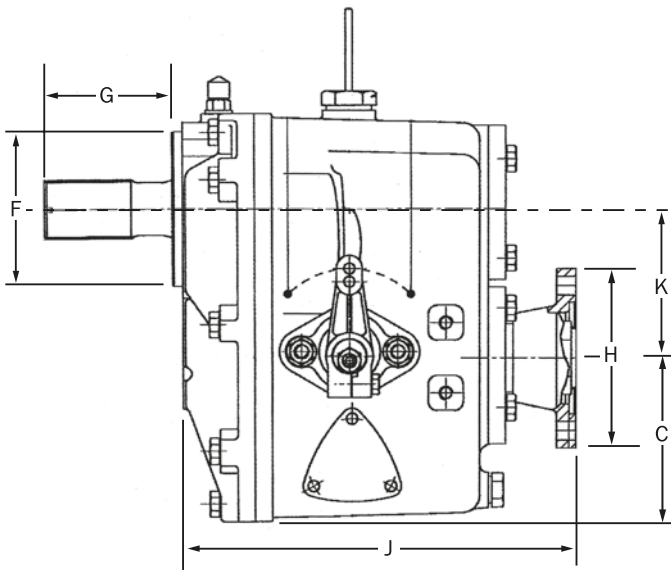

TECHNODRIVE				PRM		
TMC40 M TYPE	TMC60 M TYPE	TMC60A	TMC260	60	90	125
1.45 ⁰	1.54 ⁰	-	1.54 ⁰	[1.50 ⁰]	2.04 ⁰	2.04 ⁰
2.00 ⁰	2.00 ^[0]	2.00 ⁰	2.00 ^[A]	2.00 ⁰	[2.47 ⁰]	[2.50 ⁰]
(2.13 ^A)	[2.45 ^{0(A)}]	(2.17 ^A)	2.47 ^[A]	2.05 ^A	[2.50 ^A]	(2.50 ^A)
2.60 ⁰	(2.83 ⁰)	2.45 ⁰	(2.88 ⁰)	2.50 ⁰		[2.94 ⁰]
9	14	16	19	9	13	16
160	225	218	225	160	196	217
67.5	79	91@7°	85	67.5	72	72
63	82	71	93	70.5	76	76
88	88	88	88	88	88	88
75	75	75	80	75	75	75
4	4	4	4	4	4	4
1.0(0.7)	2.1[1.7](1.4)	1.8(1.2)	3.0(2.5)[2.0]	[0.98]0.85	1.26[1.1]	1.75(1.39)1.15
4500	5000	4500	5000	4500	4500	4500
—	—	—	—	—	—	—
Automatic transmission fluid, Dextron May be locked in astern or trailed while sailing				Automatic transmission fluid, Dextron May be locked in astern or trailed while sailing		
Made in European Community				Made in England		

⁰ indicates output rotation opposite to engine

^A is as engine rotation

Lancing Marine are able to modify any of these boxes for horizontal offset at extra charge

Installation parts available include:- Flywheel housings and adaptors, flywheel drive plates, oil coolers, shift cable connection kits, flexible couplings, shaft half couplings, C.V shafts and thrust bearings

propeller shaft thrust. Always fit a flexible coupling