

Drop centre hydraulic engagement gearboxes

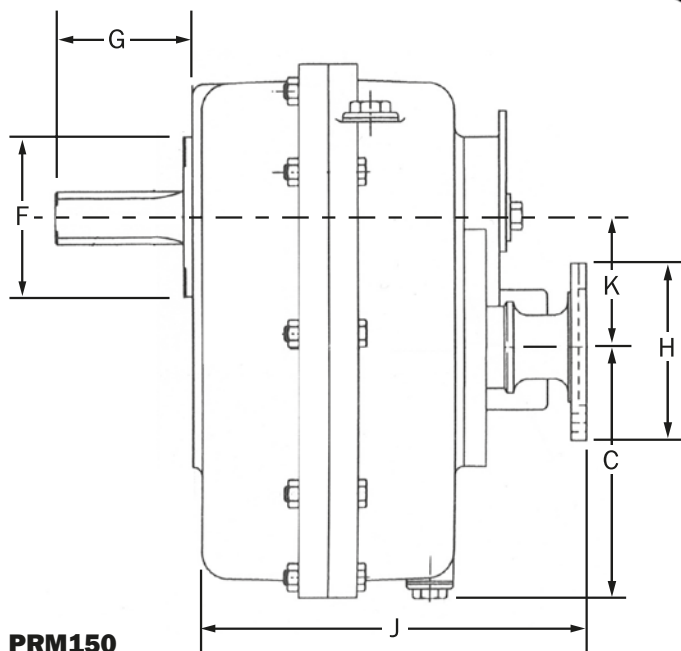

PRM150

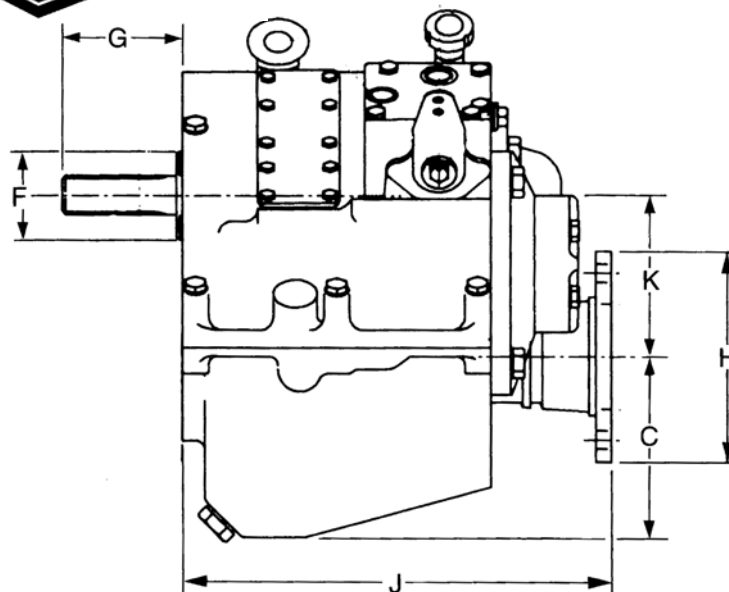

PRM280-1000

Make		PRM									
Model		150	280	500	750	750	1000	1000	1500SC**	1500DC**	
REDUCTION RATIOS :1		1.50	1.96	1.46	(1.09) (1.46)	3.95	(1.53) 2.03	4.00	1.22/1.56 1.94	3.12	
		2.10	1.94	[2.57]	[2.57]	[2.86]	[2.86]	(3.00)	2.25	3.88	
		2.82	2.94	[2.90]	[2.90]			(4.90)	2.45	4.50	
Weight	W Kgs	21	48	68	72	80	86	93	260	300	
Length	J mm	216	293	314	314	314	290	290	513	513	
Drop	K mm	74	89	121	121	153	135	174	188	248	
Depth	C mm	122	117	121	155	140	127	162	200	180	
Spigot	F mm	88	50.8	63.5	63.5	63.5	88.5	88.5	SAE3	SAE1,2	
Shaft	G mm	75	95	89	89	89	76	76	60	60	
Flange	H ins	4	5	6	6	6	6	7 ¼	7 ¼	10 ½	
Max Diesel HP/100*		2.1	3.9	6.4[6.2]	(10.5)9.5[8.0]	8.0	(14.4)12.6[11.5]	11.5	21(18.9)	21(18.3)	
Max RPM		5000	4500	4500	4500	4500	3500	3500	3000	3000	
Cooler size (min)		1	1	2	2	3	2	3	4	4	
Lubricant		Engine Oil									
*Pleasure boat rating		PT.O. available on 280 - 1750, SAE B, 13-spline Get you home device fitted After market trolling valve and electric shift available on 280 - 1750 All PRM gearboxes except 150, 1500 & 1750 may be ordered for non-standard input rotation. All gearboxes may be used with either rotation propeller. High flow oil pump available on 1000 for engines with low idle speeds					** details for 1750SC/DC identical except - power rating is 24.6, (4.9:1 - 22.5)				
		Made in England									

Installation parts available include:- Flywheel housings and adaptors, flywheel drive plates, oil coolers, shift cable connection kits, flexible couplings, shaft half couplings, C.V shafts and thrust bearings

All gearboxes may be operated with single lever remote controls, and will accept

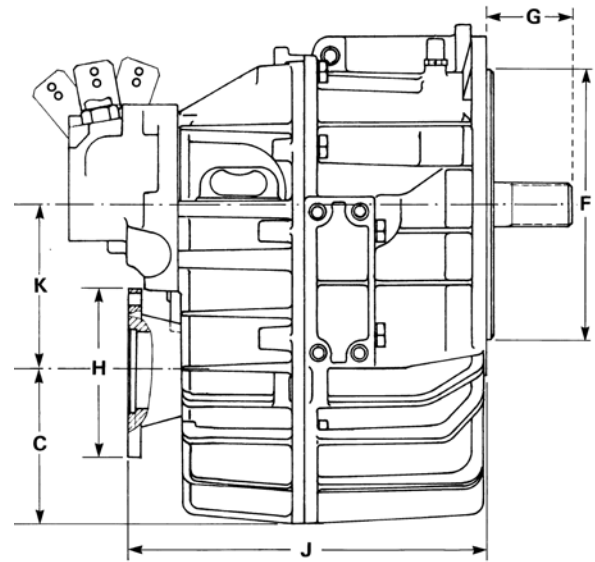
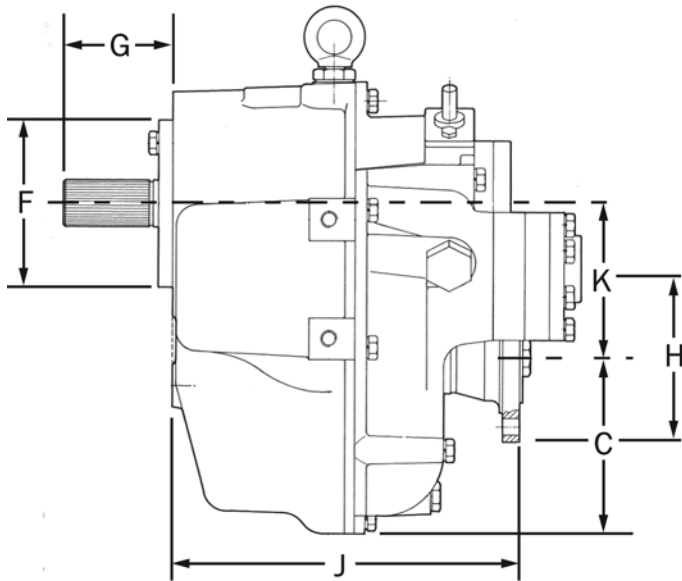

TECHNODRIVE				ZF (PREVIOUS HURTH HSW TYPES)				
345	93	170	265 ^③	25(250H)	45(450H)	63(630H)	220	280-1
(1.54)	(1.51)	(1.50)	(1.17)	1.97	2.20	1.51, 1.75	1.00	0.8, 1.00
2.00	2.09	(2.04)	1.50		2.51	1.95	1.24	1.06, 1.14
[2.47]	[2.40]	2.50	2.09		3.03	(2.48)	1.96	1.21, 1.30
[2.47]	{2.77}	[2.94]	2.82	(2.80)	3.74	(2.79)	2.48	1.51, 2.00
25	55	78	165	24	60	46	(3.00)	2.48, 3.00
255	258	253	408	270	222	273	63	73
97	110	132	158	99	151	127	287	299
95	126	131	177	101	139	119	135	146
209	120	120	SAE 1,2,3 ^①	92	111FEM	209	125	131
65	78	78	SAE11½, 14 ^①	83	74	65	111FEM	111FEM
5	5	5	5¾T.D.	4	5¾	5	95	71
(4.8)3.8[2.9]	(7.2)6.2[5.5]{4.8}	(10.4)8.4[7,2]	15	4.4(3.4)	6.3	9.6(7.9)	5¾T.D.	5¾T.D.
4500	4500	4000	300	5500	5500	5500	13.2(11.5)	18.7
1HP	2HP	2HP	3HP	1	2	1	4500	3300
SAE 20W/40 Engine Oil				ATF Dextron			SAE30 Engine Oil	
^① Not included in basic cost of gearbox ^③ P.T.O. SAE.B available				Electric shift available		PTO flanges available		
				Trolling valves available				
All gearboxes may be used with either rotation propeller.				All gearboxes may be used with either rotation propeller.				
Made in European Community				Made in European Community, except 45 (Brazil)				

Installation parts available include:- Flywheel housings and adaptors, flywheel drive plates, oil coolers, shift cable connection kits, flexible couplings, shaft half couplings, C.V shafts and thrust bearings

propeller shaft thrust. Always fit a flexible coupling