

# PRM90D

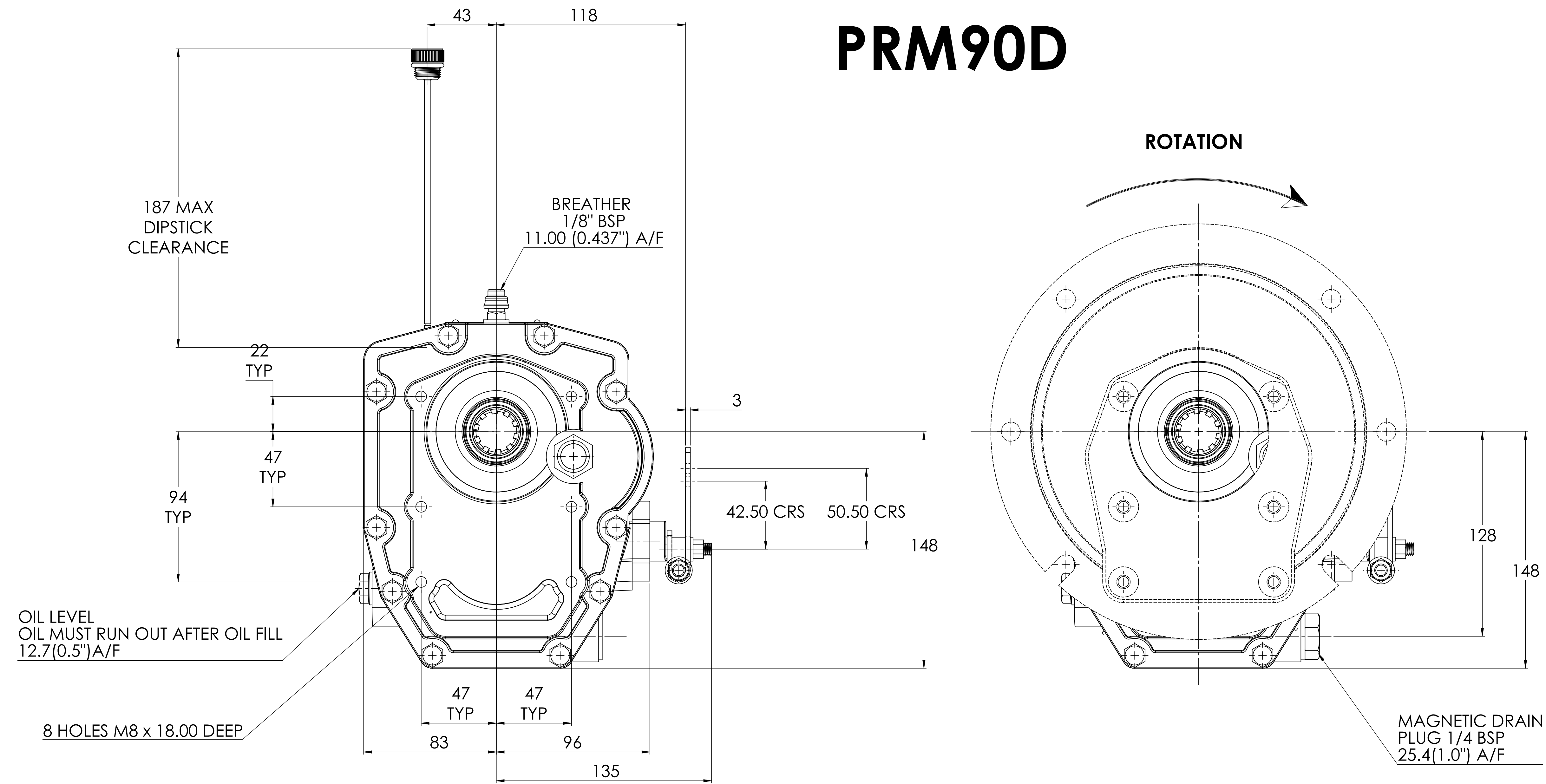

**NOTE: MOVE GEAR SELECTOR LEVER FORWARD I.E. TOWARDS GEARBOX INPUT FOR AHEAD AND REARWARDS FOR ASTERN**

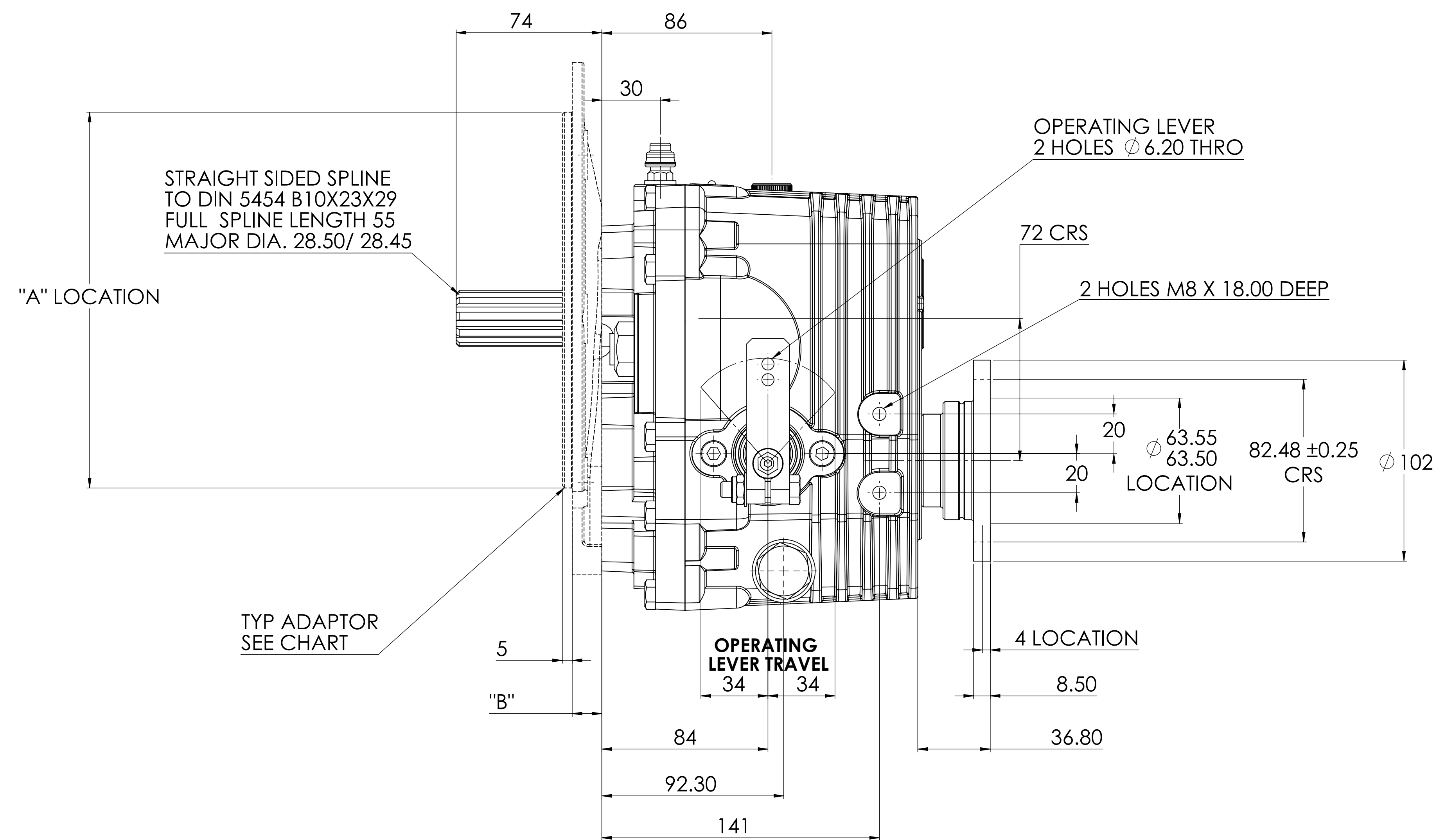

## ADAPTOR PLATES AVAILABLE

ADAPTORS	$\phi$ A	B
SAE5	314.33 (12.375")	16.0 (0.63")
B/W	209.55 (8.250")	15.0 (0.591")